



Dynapac CC1300 Plus

Double drum vibratory rollers





Technical data

 Masses	
Max. operating mass	4030 kg
Operating mass (incl. ROPS)	3900 kg
Module mass (front/rear)	1900 kg/2000 kg

 Compaction	
Centrifugal force	33 kN
Nominal amplitude	0.5 mm
Static linear load (front/rear)	14.5/15.4 kg/cm
Vibration frequency	52 Hz
Water tank	200 l

 Hydraulic system	
Driving	Axial piston pump with variable displacement. Radial piston motors (2) with constant displacement.
Vibration	Gear pump/motors with constant displacement.
Steering	Gear pump with constant displacement.
Service brake	Hydrostatic in forward and reverse lever.
Parking/ Emergency brake	Failsafe multidisc brake in both drums.

 Engine	
Manufacturer/Model	Kubota V2203-M (T4i)
Type	Water cooled
Rated power, SAE J1995	33 kW (44 hp) @ 2600 rpm
Fuel tank capacity	50 l

 Traction	
Speed range	0-10 km/h
Vertical oscillation	±10°
Theor. gradeability	37 %

Find us locally at www.dynapac.com

We reserve the right to change specifications without notice. Photos and illustrations do not always show standard versions of machines. The above information is a general description only, all informations are supplied without liability.

Dynapac CC1300 Plus

Double drum vibratory rollers



Technical data

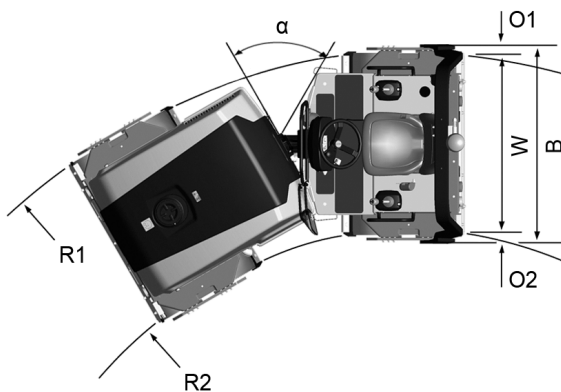
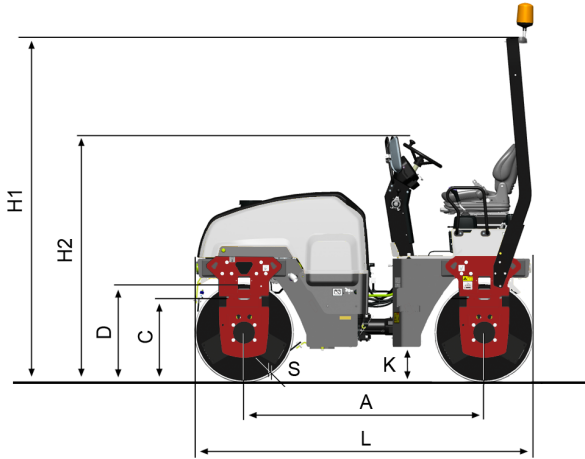

Dimensions	
A. Wheelbase	1925 mm
B. Width	1450 mm
C. Curb clearance	600 mm
D. Drum diameter	802 mm
H1. Height, with ROPS/cab	2750 mm
H2. Height, w/o ROPS/cab	1855 mm
K. Ground clearance	260 mm
L. Length	2725 mm
O1. Overhang, right	50 mm
O2. Overhang, left	50 mm
R1. Turning radius, outside	4240 mm
R2. Turning radius, inside	2940 mm
S. Drum shell thickness	16 mm
W. Drum width	1300 mm
α. Steering angle	±30°



Equipment package

CC Plus Package	Included	Optional
Backup alarm	■	
Brake release	■	
CE sign	■	
Driving lights, right or left handed		■
Dual arm rest	■	
Dual forward/reverse control		■
Dual frequency		■
Flow divider		■
Foldable ROPS incl. seatbelt	■	
Rotating beacon	■	
Rotating beacon, ignition controlled		■
Slideable comfort seat	■	
Slideable lux seat		■
Spring loaded scrapers		■
Sprinkler timer	■	
Vibr. shut off, front and rear drum	■	
Working lights	■	



Optional equipment

3" seatbelt, Biodegradable hydraulic fluid, Cert. Fire protection (SBF 127), Decal risk location (GOST), Driving lights (right and left handed), Dual forward/reverse control, Dual frequency (not for CE), Fire extinguisher, Flow divider, Foot rest, Hearing protectors, Licence plate light, Rear view mirror (traffic view), Rotating beacon (ignition controlled), Service kit 50/500/1000H, Side direction lights (driving lights required), Slide lux seat, Slow moving vehicle sign, Special color (one or two), Spring loaded scrapers, Tool set, Towing eyelet, Water tank cover (lockable)

Find us locally at www.dynapac.com

We reserve the right to change specifications without notice. Photos and illustrations do not always show standard versions of machines. The above information is a general description only, all informations are supplied without liability.